



VILLAGE OF SOUTH BARRINGTON
30 S. Barrington Road
South Barrington, IL 60010
Phone (847) 381-7510 | southbarrington.org

VEHICLE CHARGE STATION PERMIT

REQUIRED APPLICATION MATERIALS:

- Permit Application Form (southbarrington.org, Government, Building & Engineering)
 - Two (2) copies of single line diagram illustrating wiring method, size of conduit, type & size of conductors and location of charging outlet/wall charger (**see attached Single Family Residence Electric Vehicle Charger resource guide for more detail**)
 - Two (2) copies of contract proposal describing scope of work including total cost of installation
 - Provide a house load calculation
 - Two (2) copies of manufacturer product specifications & installation instructions
 - \$ 100.00 Application fee (No Credit Cards)
 - \$ 175.00 Deposit toward Plan Review Fee (No Credit Cards)
 - \$ 500.00 Refundable Performance Deposit (No Credit Cards)
-

PERMIT ISSUANCE:

Both the property owner and installer will be notified by email when the review has been completed. The Permit Card and owner's approved documents will be ready for pick-up in the Building Department. The Permit Card issued by the Building Department must be placed in a home window facing the principal roadway prior to the beginning of any work.

REQUIRED INSPECTIONS:

Inspections shall be performed by Building Officer Damian Michalski or his designee.

Required Inspections:

- 1) Electrical Rough-In
- 2) Final

PERFORMANCE BOND DEPOSIT:

A performance bond deposit (cash or check) is required from the general contractor or property owner at the time the permit is issued. The deposit return will be initiated after the final inspection is completed and approved. "Request for Release of Performance Bond Deposit" forms are available on line at www.southbarrington.org.

Resource Guide for Single Family Residence Electric Vehicle Charger

This guide shall cover the code requirements needed to provide a compliant Electric Vehicle (EV) charger in a Single-Family Residence as covered per the International Residential Code.

This guide focuses on adding an Electric Vehicle charger to an existing residence that was built prior to the Electric Vehicle Charging Act (765 ILCS 1085).

SINGLE FAMILY HOUSE ONE-LINE DIAGRAM WITH EV CHARGER

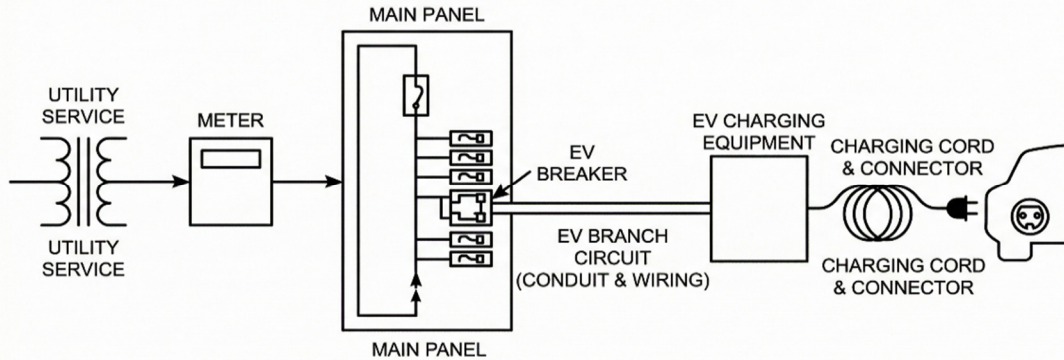

Code Requirements

This is a summary of key code requirements that are to be addressed within the technical documents.

Code Requirement	IRC 2021 & NEC 2020	IRC 2024 & NEC 2023
The residential code requires construction documents to sufficiently detail scope of work and how the provisions of the code and standards will be met.	R106, R106.1.1	R106, R106.1.1
Wall penetrations shall be sealed with appropriate materials. Typically fire stopping and fire blocking materials shall be sufficient.	R302.5.1, R302.11	R302.5.1, R302.11
Smoke Alarms and Carbon Monoxide shall be provided as for new construction. If primary power is not available per alarm or detector location and cannot be otherwise accessed and not exposed during the construction battery power is permitted.	R314.2.2, R314.6, R315.2.2, R315.6	R10.2.2, R310.6, R311.2.2, R311.6
Interconnection of smoke alarms and carbon monoxide alarms is required	R314.4, R315.5	R310.4, R311.5
EV branch circuit shall be dedicated to only EV charging equipment.	E3702.13, NEC 625.40	E3702.14, NEC 625.40
EV branch circuit shall be considered to be a continuous load	E3702.13, 625.42	E3702.14, 625.42
Electrical load calculations shall be the chargers rating. The 2024 IRC and 2023 NEC require a minimum of 7.2KW in the calculations.	E3704.2, NEC 220.40	E3704.2, NEC 220.57
EV charging coupling (the whip and plug) must be mounted at least 18" above the finished floor while inside and 24" outside	NEC 625.50	NEC 625.50
Power to cord and plug EV chargers are required from a GFCI outlet	NEC 210.8	NEC 210.8